



Closed-Horizontal Rotating Burner Development for Optimizing Palm Shell Charcoal (PSC) Production

Dafit Feriyanto^{*a}, Supaat Zakaria^b, Sagir Alva^a, Hadi Pranoto^a, Andi Firdaus Sudarma^a,
Albert Wong Phak Jie^c

^a*Department of Mechanical Engineering, Faculty of Engineering, Universitas Mercu Buana, Jakarta, Indonesia*

^b*Department of Mechanical Engineering, Politeknik Ungku Omar, Perak, Malaysia*

^c*Department of Mechanical Engineering, Faculty of Engineering Technology, Universiti Tun Hussein Onn
Malaysia, Malaysia*

Abstract. Activated Carbon (AC) was produced through several stages such as carbonization, crushing and activation process. The critical part of AC production was located at carbonization process due to burner issues that need to complete burning in short time, appropriate temperature and low cost. Therefore, this research focus on developing burner which called by closed-horizontal rotating burner. The dimension of the burner was 65 x 790 mm (D x L) with the capacity of 30 kg/carbonization process. This burner needs 1 hour for complete burning of palm shell to palm shell charcoal (PSC). Several analyses were conducted such as stress, displacement, factor of safety and thermal analysis. because this burner involved in rotation motion and high temperature operation. Physical properties have been measured which consists of moisture content (3.8-5%), ash content (7.7-8%), volatile content (53.7-56.6%) and fixed carbon content (31.3-34.7%). It can be summarized that this burner was very effective to produce PSC with short time carbonization process, low cost and complete charcoal production.

Keywords: palm shell; charcoal; burner; activated carbon

DOI: [10.37869/ijatec.v1i2.23](https://doi.org/10.37869/ijatec.v1i2.23)

Received 8 July 2020; Accepted 5 August 2020; Available online 7 August 2020

© 2020 IRIS Publisher. All rights reserved.

1. Introduction

Activated carbon (AC) is a trade name for a carbonaceous adsorbent, which could be manufactured from a variety of carbonaceous material. The application of AC adsorption system has emerged and has been identified as one of the most effective sorbent media in the purification and filtration technology especially for the removal of VOC [1]. This sorbent material also has the potential to be used in respirable particulate matter removal [2,3]

AC has truly unique properties including large surface area, high degree of surface reactivity, universal adsorption effect, and pore size which is extremely effective at gases removal and chemical adsorption [4]. Commercial activated carbon is classified into three main categories depending on the product dimension such as Powdered Activated Carbon (PWAC), Granular Activated Carbon (GAC) and Pelletized Activated Carbon (PLAC) [5]. The description of each category of AC is listed in Table 1.

AC production normally through several steps such as carbonization process, crushing process and activation process. The critical part of AC production was located at carbonization process due to it need an appropriate temperature (normally 500-1200°C) and time [6]. In addition, the burner/burner that used in carbonization process take an important part in producing AC. According

*Corresponding author: dafit.feriyanto@mercubuana.ac.id

to [7-13], they produce AC by conventional burner and laboratory burner. Therefore, it causes high cost in terms of electricity and fuel, and need long time carbonization process. The obstacle of previous research was in large/bulk quantity production. Moreover, fine AC after crushing process was dominated in previous research which it not meet requirement for water filtration process (normally 500 μm -2mm), the physical properties of the AC also inappropriate due to high ash volume which led to long time heating and cooling time of laboratory and conventional burner.

Table 1. The description of AC [5]

AC's categories	Sizes	Application
PWAC	<1.0 μm and diameter 0.15 and 0.25 μm	Gas phase adsorption
GAC	particle size which ranges from 0.5mm to 4mm.	Gas phase applications, water treatment
PLAC	Cylindrical pellets shape. Diameters in the range of 4-7 mm and 8-15 mm length.	Gas phase adsorption

2. Types of Conventional Burner

Hot tail burner has maximum diameter, height and charcoal/load of 2.8 m, 2.8 m and 4 m³, respectively. It is producing low yield and it also completed by smoke and tar emission. This burner needs 10 to 12 days [14]. Surface burner available for producing 20 m³ charcoal/cycle, diameter of 5 m and need 10 to 12 days for producing charcoal [14]. Rectangular burner has dimension of 13 x 4 x 3.5 m (l x w x h) with maximum capacity of 200-700 m³ and this burner need 15 days operation times for producing charcoal [14]. Slop burners is similar with hot tail burners with low cost and low yield not more than 25% [14]. Continuous retort conducts the burning process by hot gases from combustion system. Raw material at condition approximately of 20% humidity. The capacity of this burner was 2,000 to 10,000 t/year [14]. Working principle of a pilot rotary burner is it rotates in longitudinal axis and it operates as heat exchanger. In this system, water vapor is injected in concurrent mode as activation agent. The moisture content of raw material approximately of 5-10% and impurity content of the raw material is negligible [14]. Vertical burner designed by previous researchers [6] that has capacity of 4 kg/carbonization process. This burner fuelled by liquefied petroleum gas with burning time of 2 hours.

Table 2. Types of conventional burner



Hot tail burner



Surface burner



Rectangular burner



Continuous retort burner



Pilot rotary burner



Vertical burner

3. Proposed Burner and Analysis

Proposed burner of this research is called by closed-horizontal rotating burner (Figure 1) with the dimension of the drum is 65 x 790 mm (D x L). This burner completed by semi rotating system which purposed to uniformity carbonization process. By this burner, the carbonization time of the palm shell into palm shell charcoal was 1 hour at temperature of 400-600°C. The capacity of this burner per carbonization process is 30 kg.

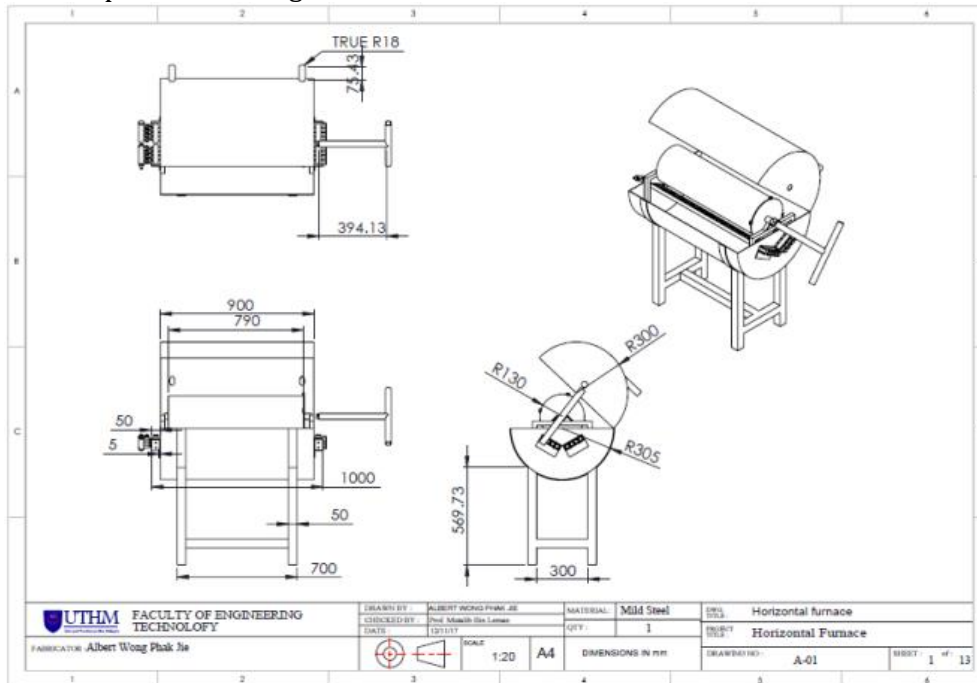

Figure 1. Design of closed-horizontal rotating burner

3.1 Stress and Displacement Analysis

The stress analysis or also known as stress-strain analysis is a method to determine the stress and strain in the material when it is subjected to a load. For this project, the load applied for the base structure is 1000N, with each end 500N. After stress analysis has been validated, the maximum and minimum stress obtained are 1.5MPa and 1.19kPa as shown in Figure 2. Since the maximum stress is smaller than yield strength of 351.6MPa, the base structure can be developed without any risk of failure.

Displacement analysis is important to know displacement of the base structure shifting from the original position after it is subjected with a load of 1000N. From Figure 3, the maximum shifting displacement is located at center of the structure with the value of 0.008mm.

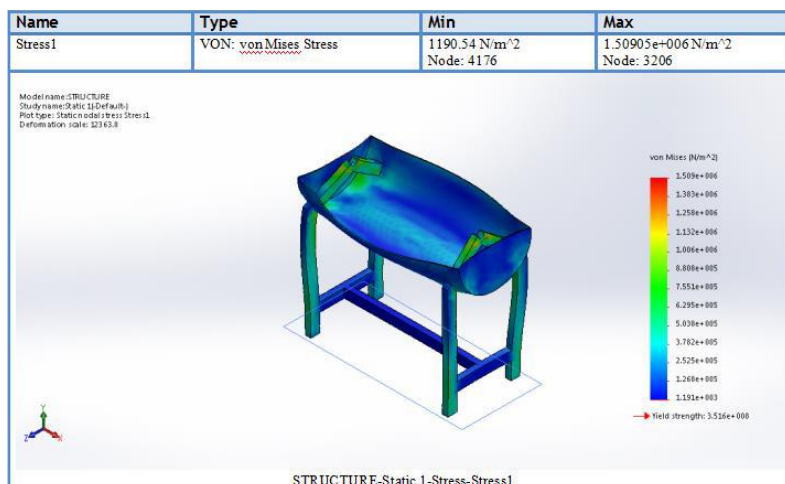

Figure 2. Stress analysis

3.2 Safety factor and thermal analysis

Factor of safety is the ratio of maximum stress of the base structure can withstand when a load of 1000N is applied on it. From the Figure 3, the minimum safety of factor is 232 which is still in allowable limit.

Thermal analysis is a branch of materials science where the properties of materials are studied as they change with temperature. For this project, the maximum heat that will apply on the surface of the cylinder is 500°C. The maximum temperature is located at the bottom part of the cylinder which is 500°C that shown in Figure 4.

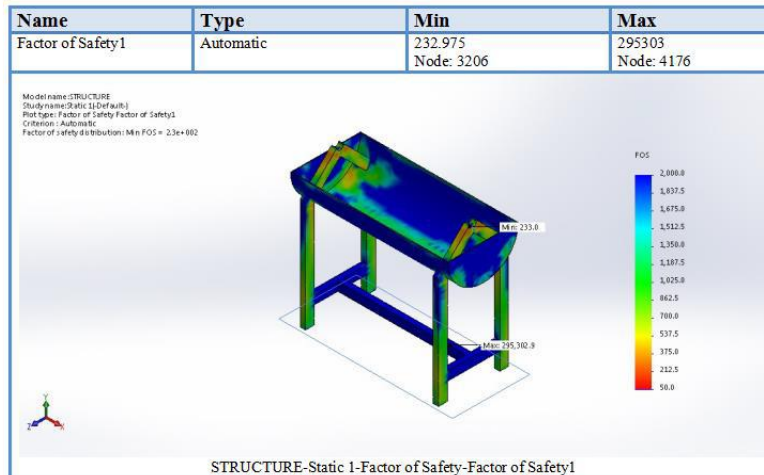

Figure 3. Factor of Safety

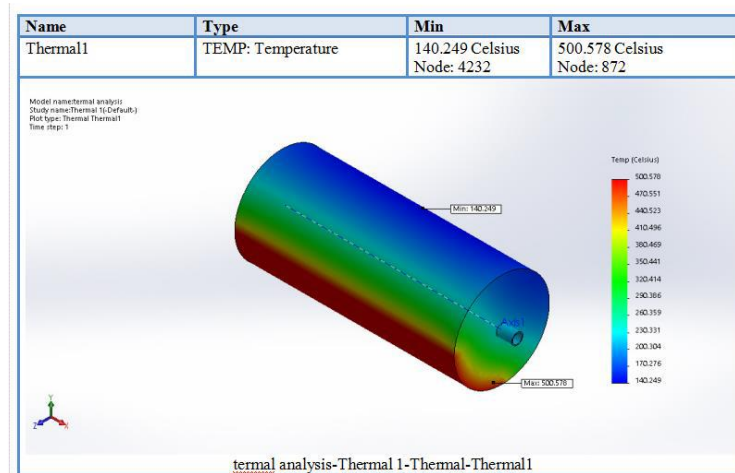

Figure 4. Thermal Analysis

3.3 Physical properties of Palm Shell Charcoal (PSC)

The physical properties of PSC which consists of moisture content, ash content, volatile content and fixed carbon content were shown in Figure 5. The moisture content of the PSC is between 3.8-5%, ash content of 7.7-8%, volatile content of 53.7-56.6% and fixed carbon content of 31.3-34.7%. The moisture content is expressed in percentage value. For many purposes, this moisture content does not affect the adsorptive power, but obviously it dilutes the carbon. Therefore, additional weight of moist carbon is needed to provide the required dry weight. Activated carbon is generally priced on a moisture free basis, although occasionally some moisture content is stipulated, e.g., 3, 8, 10%. The low and high moisture content indicate incomplete and complete carbonized palm shell. High ash content was caused by the complete carbonization process of palm shell and misocarp-fibre. Therefore, prior to the carbonization process, cleaning palm shell from misocarp-fibre needs to be performed. In terms of volatile content, uneven density in each palm shell contributed to the fluctuate volatile content as it affected the quality of carbonization process. High density decreased volatile content and influenced total porosity in each sample. High fixed carbon and low ash content required

in producing palm shell charcoal. Therefore, through this burner, low as content of 8% and fixed carbon of 34.7% were achieved.

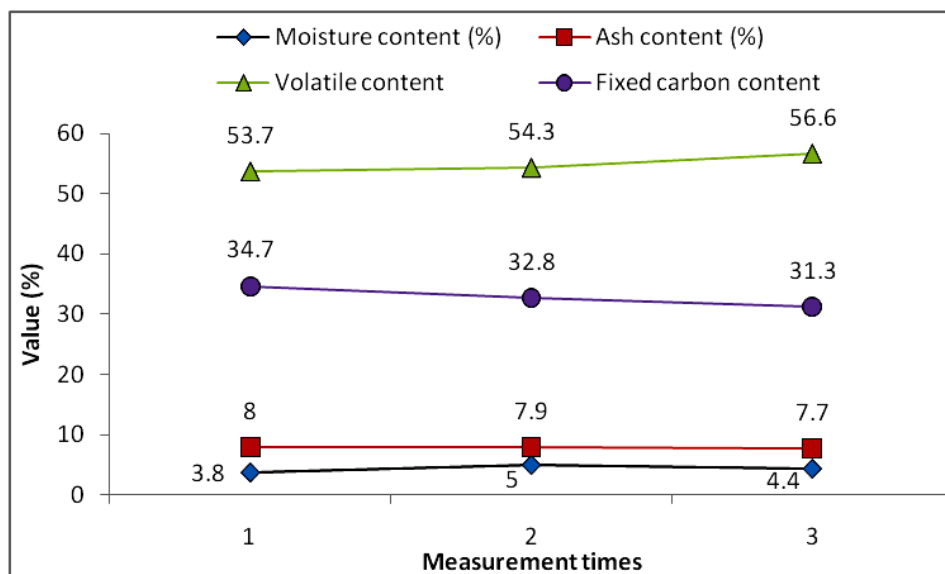

Figure 5. Physical properties of PSC that produced by closed-horizontal rotating burner

4. Conclusions

Closed-horizontal rotating burner was successfully developed. The simulation analysis such as stress, displacement, factor of safety and thermal analysis was performed in order to proof that this burner has meet the requirement in operating at high temperature up to 1200°C. Physical properties of the PSC has been investigated and the result shows that average of moisture content of 4.4%, ash content of 7.9%, volatile content is 54.9 and fixed carbon content is 32.9%.

Acknowledgment

The authors would like to thank the Universitas Mercu Buana for funding support.

References

- [1] Abechi, S.E. Gimba, C.E. Uzairu A. and Dallatu, Y.A. Preparation and Characterization of Activated Carbon from Palm Kernel Shell by Chemical Activation. *Research Journal of Chemical Sciences*, 2013;3(7):54-61.
- [2] Muala, A. Sehlstedt, M. Bion, A. Osterlund, C. Bosson, J.A. Behndig, A.F. Pourazar, J. Bucht, A. Boman, C. Mudway, I.S. Langrish, J.P. Couderc, S. Blomberg A. and Sandstrom. Assessment of the capacity of vehicle cabin air inlet filters to reduce diesel exhaust-induced symptoms in human volunteers. *Environ Health*, 2014;13(1):16.
- [3] Chew, C.M.K. Akbar, R.S. Ismail N. and Padmesh, T.V.N. Removal of PM_{2.5} and PM₁₀ using Palm Shell as Activated Carbon. *European Research and Educational Collaboration with Asia (EURECA)*, 2013.
- [4] Chambre, A. Effects of Carbon Filtration Type on Filter Efficiency and Efficacy: Granular Loose-Fill vs. Bonded Filters. *Air Science Corporation*, 2014.
- [5] Amri, N.B. Preparation of Activated Carbons from Waste Tyres Char Impregnated with Potassium Hydroxide and Carbon Dioxide Gasification. Msc. Thesis Submitted to the Department of Chemical Engineering, *Universiti Sains Malaysia*, 2008:13-14.
- [6] Zakaria, S. Leman, A.M. Dafit Feriyanto, Azmarini A. Nazri, Sunar N.M. and Mohd Najib Mohd Salleh. Burner Characteristics for Activated Carbon Production. *MATEC Web of Conference*, 2017;87:02018.
- [7] Metts T.A. and Batterman, S.A. Effect of VOC loading on the ozone removal efficiency of activated carbon filter. *Chemosphere*, 2006;62:34-44.

- [8] Sidheswaran, M.A. Destailats, H. Sullivan, D.P. Cohn S. and Fisk, W.J. Energy efficient indoor VOC air cleaning with activated carbon fiber (ACF) filter. *Building and Environment*, 2012;47:357-367.
- [9] Gallego, E. Roca, F.J. Perales J.F. and Guardino, X. Experimental evaluation of VOC removal efficiency of a coconut shell activated carbon filter for indoor air quality enhancement. *Building and Environment*, 2013;67:14-25.
- [10] Fuadi, N.A. Ibrahim A.S. and Ismail, K.N. Review study for activated carbon from palm shell used for treatment of waste water, 2008.
- [11] Wu, S. Dong, B. Qiao T. and Zhang, J. Effect of a biological activated carbon filter on particle counts. *J Zhejiang Univ Sci A*. 2008;9(1):1576-1581.
- [12] Adedayo, I. Inegbenebor A.O. and Boyo, H.I. Comparison of the Adsorptive Capacity of Raw Materials in Making Activated Carbon Filter for Purification of Polluted Water for Drinking. *ARPN Journal of Science and Technology*, 2012;2(9).
- [13] Ismaiel, A.A. Aroua M.K. and Yusoff, R. Palm shell activated carbon impregnated with task-specific ionic-liquids as a novel adsorbent for the removal of mercury from contaminated water. *Chemical Engineering Journal*, 2013;225:306-314.
- [14] Adriana, O.V. Electo, S.L. Quelbis, R.Q. Ricardo A.V. and Thalís, P.S.S. A new technology for the combined production of charcoal and electricity through cogeneration. *Biomass and bio energy*, 2014;69:222-240.